



US008537079B2

(12) **United States Patent**  
**Hekstra et al.**

(10) **Patent No.:** **US 8,537,079 B2**  
(45) **Date of Patent:** **Sep. 17, 2013**

(54) **METHOD AND APPARATUS FOR POWER CONTROL OF AN ORGANIC LIGHT-EMITTING DIODE PANEL AND AN ORGANIC LIGHT-EMITTING DIODE DISPLAY USING THE SAME**

(58) **Field of Classification Search**  
USPC ..... 345/76-77, 82-83  
See application file for complete search history.

(75) Inventors: **Gerben Hekstra**, Chu-Nan (TW); **Serve Lambie**, Chu-Nan (TW); **Ron Linsen**, Chu-Nan (TW)

(56) **References Cited**

(73) Assignee: **Chimei Innolux Corporation**, Chu-Nan (TW)

U.S. PATENT DOCUMENTS

6,160,535	A	12/2000	Park	
2003/0201727	A1 *	10/2003	Yamazaki et al.	315/169.1
2009/0195484	A1 *	8/2009	Lee et al.	345/76
2009/0278774	A1	11/2009	Chen et al.	
2010/0171774	A1 *	7/2010	Mizukoshi et al.	345/690
2010/0277513	A1 *	11/2010	Byun	345/690

(\* ) Notice: Subject to any disclaimer, the term of this patent is extended or adjusted under 35 U.S.C. 154(b) by 197 days.

FOREIGN PATENT DOCUMENTS

CN	1930603	3/2007
----	---------	--------

\* cited by examiner

(21) Appl. No.: **13/164,480**

*Primary Examiner* — Chanh Nguyen

(22) Filed: **Jun. 20, 2011**

*Assistant Examiner* — Long D Pham

(65) **Prior Publication Data**

US 2012/0019506 A1 Jan. 26, 2012

(74) *Attorney, Agent, or Firm* — Liu & Liu

**Related U.S. Application Data**

(57) **ABSTRACT**

(60) Provisional application No. 61/367,370, filed on Jul. 23, 2010.

A power control method, a power control apparatus, and an OLED display are provided. The method includes the steps of: estimating a voltage value according to image content of an image, the voltage value indicative of a minimal required voltage allowing the OLED panel to display the image; and controlling a voltage generator to adjust a booster voltage provided to the OLED panel according to the estimated voltage value.

(51) **Int. Cl.**  
**G09G 3/30** (2006.01)

**12 Claims, 6 Drawing Sheets**

(52) **U.S. Cl.**  
USPC ..... 345/76; 345/82

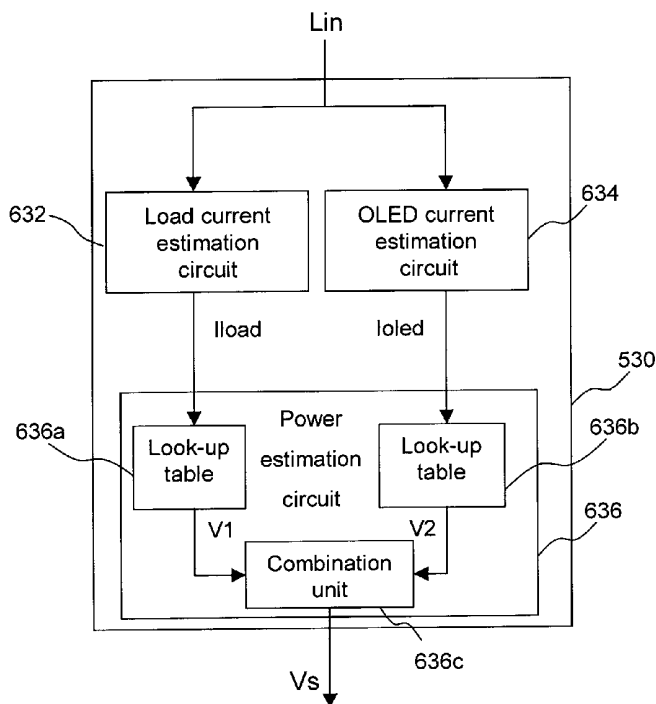

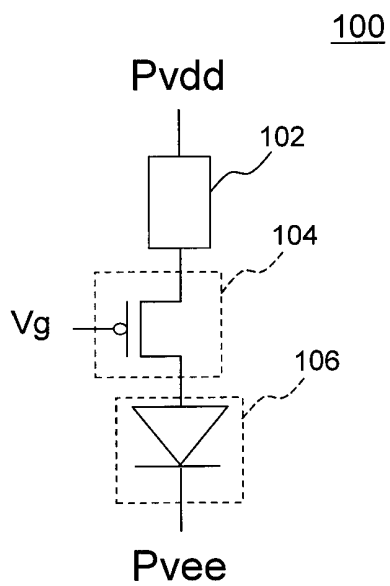

FIG. 1

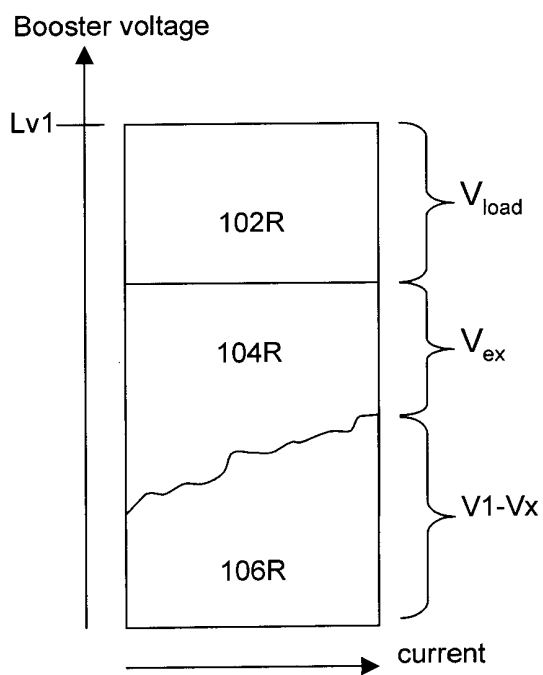

FIG. 2

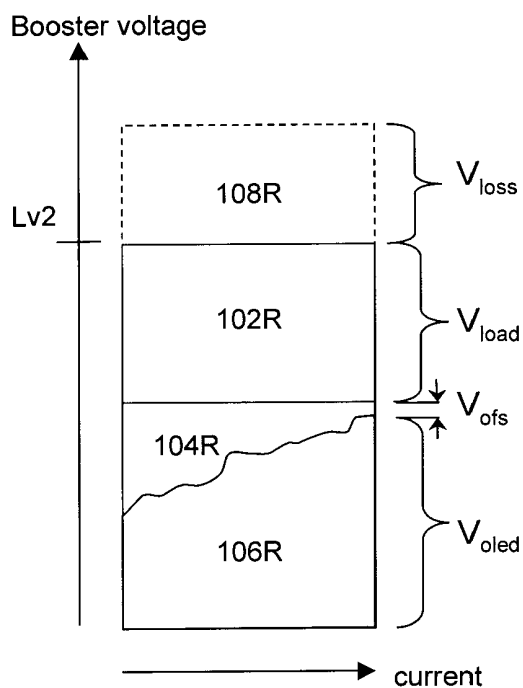

FIG. 3

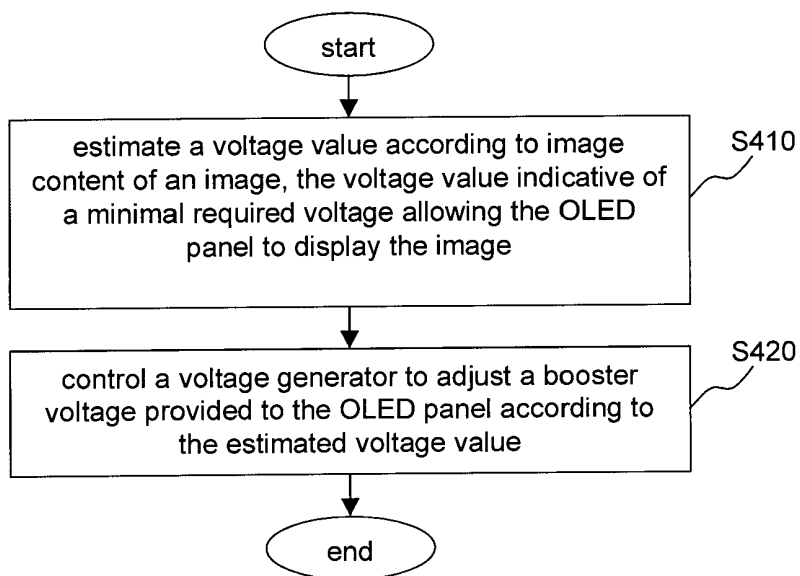

FIG. 4

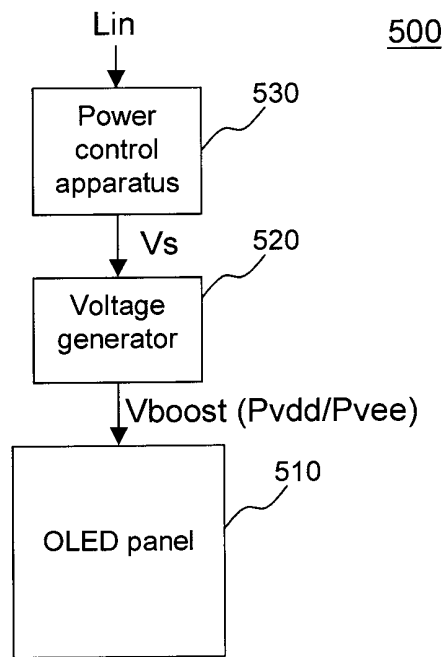

FIG. 5

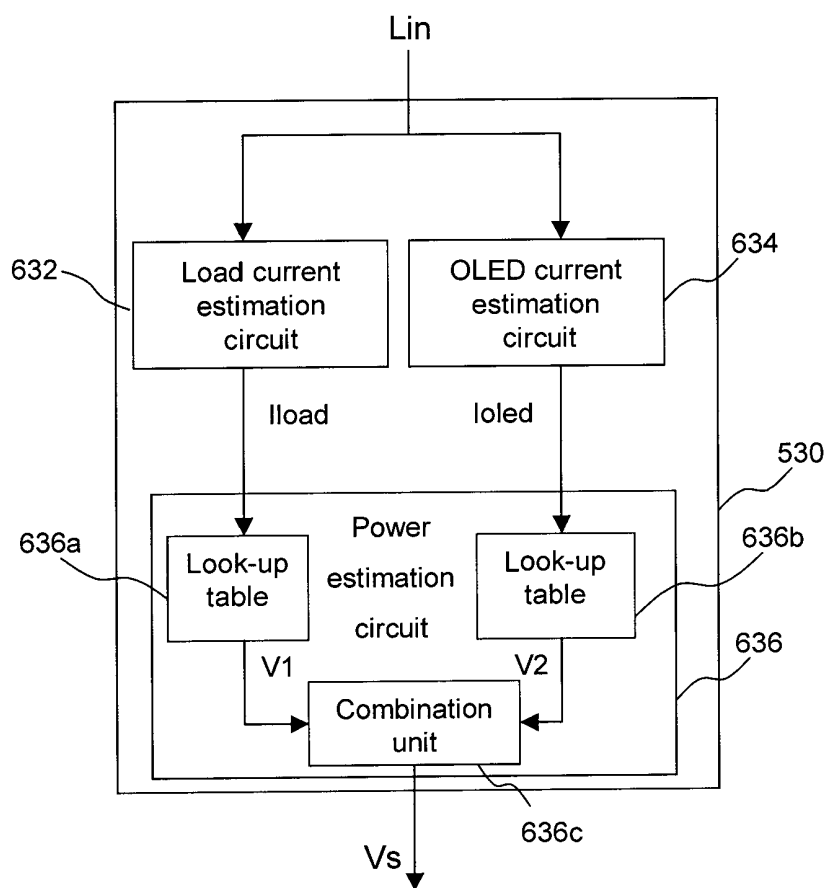

FIG. 6

632

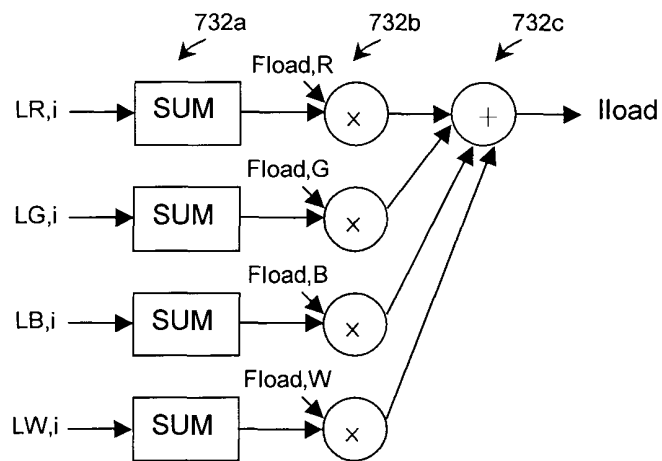

FIG. 7

634

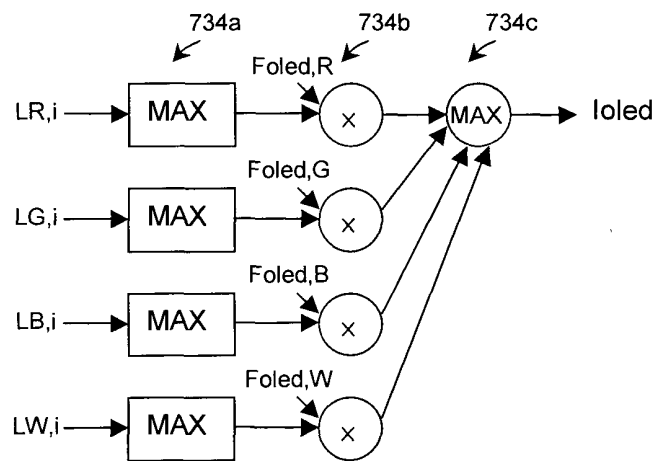

FIG. 8

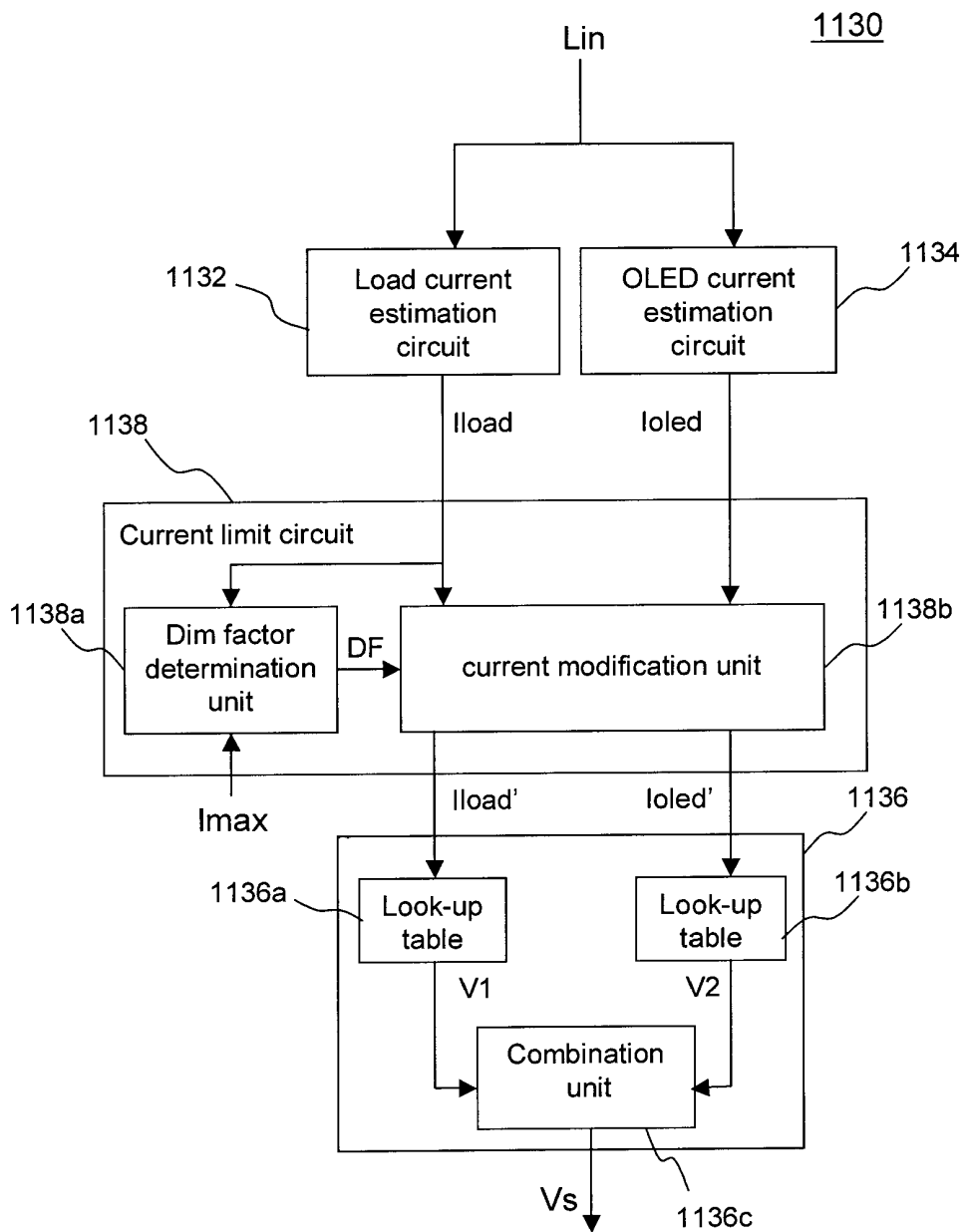

FIG. 9

**METHOD AND APPARATUS FOR POWER  
CONTROL OF AN ORGANIC  
LIGHT-EMITTING DIODE PANEL AND AN  
ORGANIC LIGHT-EMITTING DIODE  
DISPLAY USING THE SAME**

This application claims the benefit of U.S. provisional application Ser. No. 61/367,370, filed Jul. 23, 2010, the subject matter of which is incorporated herein by reference.

BACKGROUND OF THE INVENTION

1. Field of the Invention

The invention relates in general to a method and an apparatus for power control and an organic light-emitting diode (OLED) display, and more particularly to a method and an apparatus for power control and an OLED display for adjusting a booster voltage provided to an OLED panel.

2. Description of the Related Art

Generally, an organic light-emitting diode (OLED) is a self-emissive display element that emits light by electrically exciting a luminous organic compound. The OLED has recently received attention and application in the field of the flat panel display, television screens, computer displays, and portable electronic device screens. The OLED, when used in a display, lends itself to several advantages over flat-panel displays, such as its self-emissive ability which retires the backlight of the LED, wider viewing angles, and improved brightness.

The OLED-based displays, however, have a problem related to power consumption. Because of different circuit characteristics in the OLED devices, some consume more power than others. In order to assure that an OLED-based display has sufficient power to display images, the booster voltage, or the power level, is usually set at a level sufficient to allow the OLED-based display to display all kinds of images. In this way, when low brightness levels are required based on the displayed image, the level of the booster voltage remains the same. As a result, excess voltage is applied to the OLED panel, which can also be referred to that excess power that is not as demanding is used, and heat is generated. That heat is undesirable because it causes the problem of power consumption for the OLED-based display.

SUMMARY OF THE INVENTION

The invention is directed to a method and an apparatus for power control, and an organic light-emitting diode (OLED) display for adjusting a booster voltage provided from a voltage generator to an OLED panel, which can reduce power consumption for driving the OLED panel, and result in lower power loss.

According to an aspect of the present invention, a method is provided for power control of an OLED panel. The method includes the steps of: estimating a voltage value according to image content of an image, the voltage value indicative of a minimal required voltage allowing the OLED panel to display the image; and controlling a voltage generator to adjust a booster voltage provided to the OLED panel according to the estimated voltage value.

According to another aspect of the present invention, an OLED display is provided. The OLED display includes an OLED panel and a power control apparatus. The OLED panel has a number of OLED elements for displaying an image. The power control apparatus is for estimating a voltage value according to image content of the image. The voltage value is indicative of a minimal required voltage allowing the OLED

panel to display the image. The power control apparatus is for controlling a voltage generator to adjust a booster voltage provided to the OLED panel according to the estimated voltage value.

According to another aspect of the present invention, an apparatus is provided for power control of an OLED panel. The apparatus includes a load current estimation circuit, an OLED current estimation circuit, and a power estimation circuit. The load current estimation circuit is for estimating a first current value according to image content of an image, the first current value relating to a voltage drop of the OLED panel associated with the image. The OLED current estimation circuit for estimating a second current value according to the image content of the image, the second current value relating to a maximal display voltage of the OLED panel associated with the image. The power estimation circuit is for estimating a voltage value according to a combination of the estimated first current value and second current value, the voltage value indicative of a minimal required voltage allowing the OLED panel to display the image, and for controlling a voltage generator to adjust a booster voltage provided to the OLED panel according to the estimated voltage value.

The above and other aspects of the invention will become better understood with regard to the following detailed description of the preferred but non-limiting embodiment(s). The following description is made with reference to the accompanying drawings.

BRIEF DESCRIPTION OF THE DRAWINGS

FIG. 1 is a schematic diagram showing a basic panel model of an active matrix organic light-emitting diode (AMOLED) panel.

FIG. 2 is a schematic diagram showing the relationship between the booster voltage provided to the panel model in FIG. 1 and the corresponding currents associated with image content of the image.

FIG. 3 is a schematic diagram showing the relationship between the booster voltage provided to the panel model in FIG. 1 and the corresponding currents associated with image content of the image according to an embodiment of the invention.

FIG. 4 is a flow chart showing a method for driving an OLED panel according to an embodiment of the invention.

FIG. 5 is a block diagram showing an OLED display according to an embodiment of the invention.

FIG. 6 is a block diagram showing an example of a power control apparatus of the OLED display in FIG. 5 according to an embodiment of the invention.

FIG. 7 is a block diagram showing an example of a load current estimation circuit of the power control apparatus in FIG. 6 in accordance with the equation EQ. 1.

FIG. 8 is a block diagram showing an example of an OLED current estimation circuit of the power control apparatus in FIG. 6 in accordance with the equation EQ. 2.

FIG. 9 is a block diagram showing a power control apparatus of the OLED display in FIG. 5 according to another embodiment of the invention.

DETAILED DESCRIPTION OF THE INVENTION

FIG. 1 is a schematic diagram showing a basic panel model of an active matrix organic light-emitting diode (AMOLED) panel. The panel model **100** includes a panel resistance **102**, a switch circuit **104**, and an OLED circuit **106**. The panel model **100** receives different voltages including power voltage  $P_{vdd}$  and cathode voltage  $P_{vee}$ . The voltage difference between the

power voltage  $P_{vdd}$  and the cathode voltage  $P_{vee}$  represents the booster voltage of the OLED panel **100**, which can be provided from a voltage generator such as a booster. The panel resistance **102** represents a combinational resistance of various elements on the panel model **100**, such as a wiring for the power voltage  $P_{vdd}$ , a wiring for flexible printed circuit (FPC), a wiring for the cathode voltage  $P_{vee}$ , indium tin oxide (ITO) cathode plane, or electrical contact and so on. The switch circuit **104** includes a number of active switch elements such as thin film transistors (TFT). The active switch elements of switch circuit **104** receive a number of control voltages  $V_g$  converted from image data of an image, and conduct corresponding currents for the OLED circuit **106**. The OLED circuit **106** includes a number of OLED elements which correspondingly receive the currents from the switch circuit **104** and become energized to emit light as the image desired. It is apparent for those skilled in the art that the panel model **100** in FIG. 1 is provided for exemplary illustration, and OLED panels are frequently more complex than that in FIG. 1.

FIG. 2 is a schematic diagram showing the relationship between the booster voltage provided to the panel model in FIG. 1 and the corresponding currents associated with image content of the image. As shown in FIG. 2, the currents are arranged in an increasing order from left to right. The region **102R** represents a voltage drop  $V_{load}$  generated on the panel resistance **102**. The region **106R** represents a number of display voltages within a range of voltages  $V_1-V_x$ , such as 3.10-3.70V. Each display voltage is indicative of a drive voltage transmitted to or a pixel data stored across an OLED element of the OLED circuit **106** when an image or a frame is to be displayed thereon, and the display voltage is related to a current flowing therethrough. The active switch elements, when receiving the control voltages and turned on, are operated at an saturation region in which each active switch element has a substantial fixed voltage drop of about 0.5V. Because the booster voltage is usually set at a relatively high level  $L_{v1}$  in a conventional practice, a high excess voltage  $V_{ex}$  shown in region **104R** is applied across an active switch element, such as the drain-source junction of a TFT, of the switch circuit **104**, resulting in the problem of power consumption. Moreover, heat is generated due to the excess voltage  $V_{ex}$ , resulting in accelerating the degradation of the components and shortening the lifetime of the OLED panel.

FIG. 3 is a schematic diagram showing the relationship between the booster voltage provided to the panel model in FIG. 1 and the corresponding currents associated with image content of the image according to an embodiment of the invention. As shown in FIG. 3, the horizontal axis indicates the current in an increasing order from left to right. According to an embodiment of the invention, the booster voltage is set at a level associated with the image content and sufficient to allow the OLED panel to display the image, which can also be regarded as each frame or one frame of a video, while the level is adjusted with respect to different images containing different image content. In other words, as shown in FIG. 3, the booster voltage can be set at a lower level  $L_{v2}$  than the level  $L_{v1}$ , and the level  $L_{v2}$  of the booster voltage can be determined according to the image content of the image from different voltages of the OLED panel. For example, the level  $L_{v2}$  can be determined from three voltages measurable on the OLED panel: (1) the voltage drop  $V_{load}$  on the panel resistance **102**; (2) the voltage drop on the switch circuit **104** which can be regarded as an offset voltage  $V_{ofs}$  about 0.5V; and (3) a maximum display voltage  $V_{oled}$  among the display voltages of the OLED elements of the OLED circuit **106**. In this way, the booster voltage can be adjusted according to the

to-be-display image, so that excess voltage  $V_{loss}$  shown in region **108R** can be reduced, making it possible to reduce power consumption for driving the OLED panel, and to lessen power loss.

FIG. 4 is a flow chart showing a method for driving an OLED panel according to an embodiment of the invention. The method is used for power control of an OLED panel. The method includes the following steps. In step **S410**, a voltage value is estimated according to image content of an image, the voltage value indicative of a minimal required voltage allowing the OLED panel to display the image. In step **S420**, a voltage generator is controlled to adjust a booster voltage provided to the OLED panel according to the estimated voltage value.

According to the aforementioned method for driving the OLED panel, a voltage value, which is indicative of a minimal required voltage sufficient for the OLED panel to display the image, is estimated and used to adjust the booster voltage provided to the OLED panel. Using the voltage value indicative of the minimal required voltage means the booster voltage can be adjusted to an adequate level as a function of the image content, so as to reduce power consumption. Therefore, driving the OLED panel according to the embodiment can result in reduced power consumption.

FIG. 5 is a block diagram showing an OLED display according to an embodiment of the invention. The OLED display **500** includes an OLED panel **510**, a voltage generator **520**, and a power control apparatus **530**. The OLED panel **510** has a number of OLED elements for displaying an image and a number of switch elements, while each of the switch element and a corresponding OLED element are defined as a sub-pixel, which is well known in the art. In a practical example, the OLED panel can be a white OLED panel with RGBW color filters, or a side-by-side (SBS) OLED panel where R, G, B OLED materials are deposited in a manner of side-by-side to form patterned RGB sub-pixels, but this invention is not limited thereto. The voltage generator **520** provides a booster voltage  $V_{boost}$  to the OLED panel **510**. The booster voltage  $V_{boost}$  is for example represented by the voltage difference between the power voltage  $P_{vdd}$  and the cathode voltage  $P_{vee}$  shown in FIG. 1. The power control apparatus **530** estimates a voltage value  $V_s$  according to image content  $L_{in}$  of the image. The image content  $L_{in}$  can be for example image data of the image, or other information retrieved from a portion of image data or all the image data of the image. The voltage value  $V_s$  is indicative of a minimal required voltage allowing the OLED panel **510** to display the image. The minimal required voltage can be for example the booster voltage being set at the level  $L_{v2}$  in FIG. 3. According to the estimated voltage value  $V_s$ , the power control apparatus **530** controls the voltage generator **520** to adjust the booster voltage  $V_{boost}$  provided to the OLED panel **510**. For example, the power control apparatus **530** can use the voltage value  $V_s$  to modify the voltage setting of the voltage generator **520**, causing the voltage generator **520** to set the booster voltage  $V_{boost}$  at the level  $L_{v2}$ .

FIG. 6 is a block diagram showing an example of a power control apparatus of the OLED display in FIG. 5 according to an embodiment of the invention. The power control apparatus **530** includes a load current estimation circuit **632**, an OLED current estimation circuit **634**, and a power estimation circuit **636**. The load current estimation circuit **632** estimates a first current value  $I_{load}$  according to the image content  $L_{in}$ . The first current value  $I_{load}$  is for example indicative of a load current flowing through the OLED panel associated with the image. The OLED current estimation circuit **634** estimates a second current value  $I_{oled}$  according to the image content

Lin. The second current value I<sub>oled</sub> is for example indicative of a maximal current flowing through one of the OLED elements of the OLED panel 510 associated with the image.

In a practical example, in order for the power control apparatus 530 in FIG. 6 to estimate current values I<sub>load</sub> and I<sub>oled</sub>, the image content Lin can be the information of luminance values converted from the image data of the image. As to an AMOLED, the current flowing through a single pixel can be estimated as a value proportional to the square of its drive voltage, and linearly proportional to the luminance of its sub-pixels. In other words, in the example of FIG. 6, the luminance value of a sub-pixel, which is converted from the square value of a piece of raw image data, is served as the image content Lin and provided to the current estimation circuits 632 and 634 for current estimation. However, this invention is not limited thereto. The conversion from image data to luminance can be completed in another example where the gamma correction is taken into consideration. In addition to the luminance, the image content Lin can be other information which a person having ordinary skill in the art could use to estimate the current values.

As to the operation of the current estimation circuits 632 and 634, estimating the current values I<sub>load</sub> and I<sub>oled</sub> involve a weighted summation which is related to the converted luminance values and a number of weighting values. Further description is provided as follows for illustration.

In an embodiment, the first current value I<sub>load</sub> is estimated according to a number of sub-pixel luminance values and a number of corresponding weighting values. Each sub-pixel luminance value can be converted from a corresponding primary color sub-pixel data. For example, it is exemplified that the OLED panel 510 includes four kinds of primary color sub-pixel each including an OLED element and a corresponding active switch element, and the first current value I<sub>load</sub> can be estimated in accordance with the equation EQ. 1 as follows:

$$I_{load} = \sum_{x=R,G,B,W} F_{load,x} \cdot \sum_{i=1 \dots N} L_{x,i} \tag{EQ. 1}$$

wherein I<sub>load</sub> represents the first current value I<sub>load</sub>; L<sub>x,i</sub> (x=R, G, B, W)(i=1:N) represent four sub-pixel luminance values for N pixels; and F<sub>load,x</sub>(x=R, G, B, W) represent four weighting values for the four sub-pixel luminance values.

FIG. 7 is a block diagram showing an example of a load current estimation circuit of the power control apparatus in FIG. 6 in accordance with the equation EQ. 1. The load current estimation circuit 632 includes four summation units 732a, four multipliers 732b, and a summation and output unit 732c. The four summation units 632a receive and sum up four primary color sub-pixel data LR,i, LG,i, LB,i, LW,i, and transmit their results to the four multipliers 732b, respectively. The four multipliers 732b multiply the results of the summation units 732b with four weighting values F<sub>load,R</sub>, F<sub>load,G</sub>, F<sub>load,B</sub>, F<sub>load,W</sub>, respectively. The summation and output unit 732c receives and sums up the results of the four multipliers 732b, thus providing the first current value I<sub>load</sub>.

In an embodiment, the second current value I<sub>oled</sub> is estimated according to a number of sub-pixel luminance values and a number of corresponding weighting values. As is similar to the aforementioned example of estimating the first current value I<sub>load</sub> where the OLED panel 510 includes four

kinds of primary color sub-pixel, the second current value I<sub>oled</sub> can be estimated in accordance with the equation EQ. 2 as follows:

$$I_{oled} = \max_{x=R,G,B,W} (F_{oled,x} \cdot \max_{i=1 \dots N} L_{x,i}) \tag{EQ. 2}$$

wherein I<sub>oled</sub> represents the second current value I<sub>oled</sub>; L<sub>x,i</sub> (x=R, G, B, W)(i=1:N) represent four sub-pixel luminance values for N pixels; and F<sub>oled,x</sub>(x=R, G, B, W) represent four weighting values for the four sub-pixel luminance values.

FIG. 8 is a block diagram showing an example of an OLED current estimation circuit of the power control apparatus in FIG. 6 in accordance with the equation EQ. 2. The OLED current estimation circuit 634 includes four maximum units 734a, four multipliers 734b, and a maximum and output unit 734c. The four maximum units 734a receive and obtain four maximum from four primary color sub-pixel data LR,i, LG,i, LB,i, LW,i, and transmit their results to the four multipliers 734b, respectively. The four multipliers 734b multiply the results of the maximum units 734b with four weighting values F<sub>oled,R</sub>, F<sub>oled,G</sub>, F<sub>oled,B</sub>, F<sub>oled,W</sub>, respectively. The maximum and output unit 734c receives and obtain a maximum from the results of the four multipliers 734b, thus providing the second current value I<sub>oled</sub>.

As to the implementation of the summation units 732a, the maximum units 734a, and the output unit 732c and 734c, their circuit architectures can be implemented by logistic elements such as adders, flip-flops, and/or comparators connected in open and/or closed loops. It is apparent for those skilled in the art to implement such devices or circuits which perform the function based on equations EQ. 1 and EQ. 2.

Based on the equations EQ. 1 and EQ. 2, the OLED panel 510 is exemplified as including four kinds of primary color sub-pixel. However, this invention is not limited thereto. In another embodiment, the OLED panel 510 can also be implemented as one which includes three kinds primary color sub-pixel, such as RGB sub-pixels where R, G, B OLED materials are deposited thereon. In this way, each of the equations EQ. 1 and EQ. 2 can be accordingly modified as one where x=R, G, B. Besides, the weighting values for each primary color sub-pixel can also provide the flexibility to circuit design. For example, the weighting values can be the same or different or can be determined according to the aperture sizes or the layout areas of these primary color sub-pixels.

The power control apparatus mentioned in above examples is exemplified to deal with all the image data of the image, but this invention is not limited thereto. In another embodiment, instead of dealing with all the image data of the image, the power control apparatus can also deal with a portion of image data so as to determine the voltage value. For example, the power control apparatus can calculate a weighted summation and maximum of a portion of sub-pixel luminance values, and normalize the calculation results to estimate the first current value I<sub>load</sub> and the second current value I<sub>oled</sub>. It is apparent for those skilled in the art that the image content can be retrieved from a portion of image data or all the image data of an image. Any estimation approach of the minimal required voltage and any adjustment to the booster voltage as a function of the image content of the image are regarded as a practicable embodiment of the invention.

Referring to FIG. 6, the power estimation circuit 636 estimates a first voltage value V1 indicative of the voltage drop V<sub>load</sub> in FIG. 1 according to the estimated first current value I<sub>load</sub>, and estimates a second voltage value V2 indicative of

the maximal display voltage  $V_{oled}$  according to the estimated second current value  $I_{oled}$ . In an embodiment, the power estimation circuit **636** includes two look-up tables **636a** and **636b**. The power estimation circuit **636** determines the first voltage value  $V1$  according to the first current value  $I_{load}$  and the look-up table **636a**, and determines the second voltage value  $V2$  according to the second current value  $I_{oled}$  and the look-up table **636b**. In accordance with the resistive relationship between voltages and currents, i.e.  $V=R*I$ , the first voltage value  $V1$  and the second voltage value  $V2$  can be obtained in a manner of using multipliers each containing a gain indicative of the resistive relationship between voltage and current. To take nonlinear effect into account, conversion of voltage and current in this embodiment can be implemented as look-up tables which contain voltage values and current values establishing the corresponding relationship between voltages and currents, i.e.  $V=LUT(I)$ . In a practical example, the look-up tables **636a** and **636b** can be obtained from experimental results and designed to meet different requirements.

In this embodiment, the power estimation circuit **636** can also include a combination unit **636c**, with which the power estimation circuit **636** can determine the voltage value  $V_s$  indicative of the minimal required voltage according to a combination of the estimated first voltage value  $V1$  and second voltage value  $V2$ . In another embodiment, the power estimation circuit **636** can further estimate an offset voltage value. The offset voltage value is indicative of an offset voltage such as the offset voltage  $V_{ofs}$  shown in FIG. 3 which allows the switch elements of the OLED panel **510** to operate in saturation mode. The offset voltage  $V_{ofs}$  is for example about 0.5V. The offset voltage  $V_{ofs}$  can be transmitted to the combination unit **636c** (not shown in FIG. 6) for making its combination estimation. As such, the power estimation circuit **636** can determine the voltage value  $V_s$  indicative of the minimal required voltage according to a combination of the first voltage value  $V1$ , the second voltage value  $V2$ , and the offset voltage value  $V_{ofs}$ , thus providing a resulted voltage being set at the level  $V_{p2}$  as shown in FIG. 3.

Moreover, in another embodiment, the OLED display **500** can further include a driver integrated chip (IC) not shown in the drawings. The drive IC uses the image content  $I_{in}$  to drive the OLED panel **510**, so as to display the image. For example, the drive IC can convert the raw image data into corresponding control voltages such as the control voltages  $V_g$  shown in FIG. 1. In this embodiment, the power control apparatus of this embodiment can be implemented in the drive IC, but this embodiment is not limited thereto. The power control apparatus can also be implemented in another place capable of receiving the image content and controlling the voltage generator.

FIG. 9 is a block diagram showing a power control apparatus of the OLED display in FIG. 5 according to another embodiment of the invention. In this embodiment, as is similar to the power control apparatus **530** in FIG. 6, the power control apparatus **1130** includes a load current estimation circuit **1134** and an OLED current estimation circuit **1134**, whose operation will not be repeated for the sake of brevity. The power control apparatus **1130** further includes a current limit circuit **1138**. The current limit circuit **1138** limits the estimated first current value  $I_{load}$  and the estimated second current value  $I_{oled}$ . The current limit circuit **1138** includes a dim factor determination unit **1138a** and a current modification unit **1138b**. The dim factor determination unit **1138a** determines a dim factor  $DF$  according to a ratio of a limit current value  $I_{max}$  and the first current value  $I_{load}$ . The limit current value  $I_{max}$  can be a user-defined value or can be

adjusted to meet different requirements. The current modification unit **1138b** modifies the first current value  $I_{load}$  and the second current value  $I_{oled}$  according to the dim factor  $DF$ . For example, the current modification unit **1138b** can be a multiplier, which multiplies the first current value  $I_{load}$  and the second current value  $I_{oled}$  respectively with a gain represented by the dim factor  $DF$ , and produces the limited first current value  $I_{load}'$  and the limited second current value  $I_{oled}'$ . Receiving the limited first current value  $I_{load}'$  and the limited second current value  $I_{oled}'$ , the power estimation circuit **1136** determines the first voltage value  $V1$  and the second voltage value  $V2$  according to the look-up tables **1136a** and **1136b**, and determines the voltage value  $V_s$  indicative of the minimal required voltage according to a combination of the estimated first voltage value  $V1$  and second voltage value  $V2$ .

Besides, the power requirements for OLED elements to maintain the same level of luminance may increase with age due to their degradation. To compensate for the degradation of OLED elements and the aging OLED panel, the power control apparatus of this embodiment can control the voltage generator to adjust the level of the booster voltage adequately in response to the measured current or the measured luminance or brightness of the OLED elements. For example, the embodiment can further include a detector and a compensation look-up table (no shown). The detector can be used to detect the measured current or the measured luminance or brightness of the OLED elements. The compensation look-up table can be used to provide the relationship between the booster voltage and the current flowing through the OLED element or the luminance measured therefrom, the stored content of which the power control apparatus can use to determine the voltage value indicative of the minimal required voltage. As compared with a conventional practice which initially sets booster voltage at a relatively high level, the embodiment using the detector and the compensation look-up table gradually increases the booster voltage provided to the OLED panel to compensate for the degradation of OLED elements and the aging OLED panel, so as to drive the OLED panel with reduced booster voltage and lower power loss.

According to the OLED display and the method for driving the same disclosed in the embodiment of the invention, the booster voltage provided to the OLED panel is adjusted, based on the image content, to an adequate level for allowing the OLED panel to display the image, so that excess voltage can be reduced. Therefore, lower power loss and higher power efficiency can be achieved. Moreover, the lifetime of the OLED display can be lengthened due to the reduced booster voltage.

While the invention has been described by way of example and in terms of the preferred embodiment(s), it is to be understood that the invention is not limited thereto. On the contrary, it is intended to cover various modifications and similar arrangements and procedures, and the scope of the appended claims therefore should be accorded the broadest interpretation so as to encompass all such modifications and similar arrangements and procedures.

What is claimed is:

1. A method for power control of an organic light-emitting diode (OLED) panel, comprising:

- estimating a voltage value according to an image data of an image, the voltage value indicative of a minimal required voltage allowing the OLED panel to display the image;
- estimating a first current value according to a plurality of luminance values converted from the image data, the

first current value indicative of a load current flowing through the OLED panel associated with the image;  
 estimating a second current value according to the plurality of luminance values converted from the image data, the second current value indicative of a maximal current flowing through one of a plurality of OLED elements of the OLED panel associated with the image;  
 estimating a first voltage value according to the estimated first current value, the first voltage value indicative of a voltage drop of the OLED panel associated with the image;  
 estimating a second voltage value according to the estimated second current value, the second voltage value indicative of a maximal display voltage of the OLED panel associated with the image;  
 determining the voltage value indicative of the minimal required voltage according to a combination of the estimated first voltage value and the estimated second voltage value; and  
 controlling a voltage generator to adjust a booster voltage provided to the OLED panel according to the voltage value indicative of the minimal required voltage.

2. The method according to claim 1, wherein in the step of estimating the first current value according to the plurality of luminance values converted from the image data of the image, the first current value is estimated according to a plurality of sub-pixel luminance values and a plurality of corresponding weighting values.

3. The method according to claim 1, wherein the first voltage value is determined according to the first current value and a look-up table.

4. The method according to claim 1, wherein in the step of estimating the second current value according to the plurality of luminance values converted from the image data, the second current value is estimated according to a plurality of sub-pixel luminance values and a plurality of corresponding weighting values.

5. The method according to claim 1, wherein the second voltage value is determined according to the second current value and a look-up table.

6. The method according to claim 1, wherein the step of estimating the first voltage value comprises:  
 determining the first voltage value indicative of the voltage drop according to the estimated first current value;  
 wherein the step of estimating the second voltage value comprises:  
 determining the second voltage value indicative of the minimal required voltage according to the estimated second current value.

7. The method according to claim 6, further comprises:  
 limiting the estimated first current value and the estimated second current value,  
 wherein in the steps of determining the first voltage value and the second voltage value, the first voltage value and the second voltage value are determined according to the limited first current value and the limited second current value, respectively.

8. The method according to claim 7, wherein the step of limiting the estimated first value and the estimated second value comprises:  
 determining a dim factor according to a ratio of a limit current value and the first current value; and  
 modifying the first current value and the second current value according to the dim factor.

9. An organic light-emitting diode (OLED) display, comprising:  
 an OLED panel having a plurality of OLED elements for displaying an image;  
 a load current estimation circuit for estimating a first current value according to a plurality of luminance values converted from an image data of the image, the first current value indicative of a load current flowing through the OLED panel associated with the image;  
 an OLED current estimation circuit for estimating a second current value according to the plurality of luminance values converted from the image data of the image, the second current value indicative of a maximal current flowing through one of a plurality of OLED elements of the OLED panel associated with the image;  
 a power estimation circuit for determining an estimated first voltage value indicative of the voltage drop according to the estimated first current value and determining an estimated second voltage value indicative of the maximal display voltage according to the estimated second current value; and  
 a power control apparatus for estimating a voltage value according to the image data of the image, the voltage value indicative of a minimal required voltage allowing the OLED panel to display the image, and for controlling a voltage generator to adjust a booster voltage provided to the OLED panel according to the estimated first voltage value and the estimated second voltage value.

10. The display according to claim 9, wherein the second current value is estimated according to a plurality of sub-pixel luminance values and a plurality of corresponding weighting values.

11. An apparatus for power control of an organic light-emitting diode (OLED) panel, comprising:  
 a load current estimation circuit for estimating a first current value according to an image data of an image, the first current value relating to a voltage drop of the OLED panel associated with the image;  
 an OLED current estimation circuit for estimating a second current value according to the image data of the image, the second current value relating to a maximal display voltage of the OLED panel associated with the image;  
 a power estimation circuit for estimating a voltage value according to a combination of the estimated first current value and the estimated second current value, the voltage value indicative of a minimal required voltage allowing the OLED panel to display the image, and for controlling a voltage generator to adjust a booster voltage provided to the OLED panel according to the estimated voltage value;  
 a current limit circuit for limiting the estimated first current value and the estimated second current value; and  
 wherein the power estimation circuit determines the voltage value according to the limited first current value and the limited second current value.

12. The apparatus according to claim 11, wherein current limit circuit comprises:  
 a dim factor determination unit for determining a dim factor according to a ratio of a limit current value and the first current value; and  
 a current modification unit for modifying the first current value and the second current value according to the dim factor.

\* \* \* \* \*

专利名称(译)	用于有机发光二极管面板的功率控制的方法和设备以及使用该方法和设备的有机发光二极管显示器		
公开(公告)号	<a href="#">US8537079</a>	公开(公告)日	2013-09-17
申请号	US13/164480	申请日	2011-06-20
[标]申请(专利权)人(译)	群创光电股份有限公司		
申请(专利权)人(译)	奇美群创光电		
当前申请(专利权)人(译)	群创光电		
[标]发明人	HEKSTRA GERBEN LAMBIE SERVE LINSSEN RON		
发明人	HEKSTRA, GERBEN LAMBIE, SERVE LINSSEN, RON		
IPC分类号	G09G3/30		
CPC分类号	G09G3/3233 G09G2360/16 G09G2330/021 G09G2320/0223		
审查员(译)	阮箐		
优先权	61/367370 2010-07-23 US		
其他公开文献	US20120019506A1		
外部链接	<a href="#">Espacenet</a> <a href="#">USPTO</a>		

摘要(译)

提供了一种功率控制方法，功率控制设备和OLED显示器。该方法包括以下步骤：根据图像的图像内容估计电压值，该电压值指示允许OLED面板显示图像的最小所需电压；根据估计的电压值控制电压发生器调节提供给OLED面板的升压电压。

